

ENVIROGRAF® PRODUCT 14

INTUMESCENT FAN COVERS



DESCRIPTION

An intumescent grille unit available in two types: wall mounted and glass mounted.

USE

Fan cover units can be installed over VentAxia, Xpelair, or other makes of wall or window fans, giving fire and smoke protection to escape corridors and staircase fire escapes.

PERFORMANCE

Contains a front MG grille, giving up to 73 minutes integrity to BS476 Parts 20 & 22 (1987). Also tested at VNE to European Standard EN1363-1 (2000).

ORDERING REFERENCES:

PATENTED

FCW Wall-mounted
FCG Glass-mounted

Add suffix /X for Xpelair plus the model, catalogue number, and fan size

Add suffix /V for VentAxia plus the model, catalogue number, and fan size

When ordering fan covers, please allow a minimum 25mm clear gap around the fan mouldings for ease of fixing and wiring.

Can also be supplied with smoke shutters with 24V electro-magnet with automatic re-set solenoid. Fan cover required under Building Regulations and 17th Edition of IEE Regulations

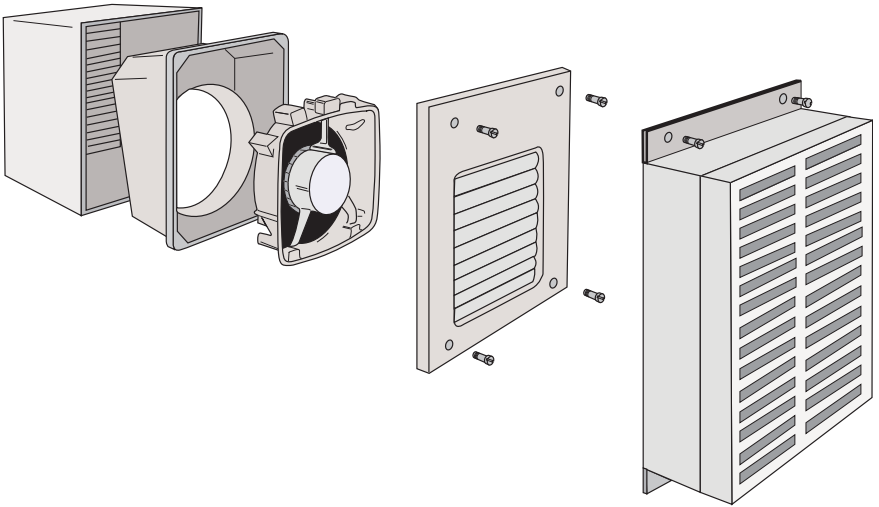

See also Product 33 Firoblok® sleeves for air conditioning/ventilation outlet protection.