

Flexiseal

RIW Flexiseal is a solvent free thixotropic liquid based on urethane pre-polymers, which on contact with atmospheric moisture, cures to give a continuous tough rubber-like coating.

RIW Flexiseal Primer is a solvent free brown liquid pre-polymer based on M.D.I.

BENEFITS

- Water and water vapour barrier
- Colour coded quality control system
- Dry film thickness may be measured
- Fully bonded
- Cold applied, jointless membrane
- Fast curing, Elastic and flexible
- Easily applied to difficult profiles

APPLICATIONS

Waterproofing and vapour proofing of:

- Basement and Sub-structures
- Deck areas
- Retaining walls
- Ground floors
- Reservoirs
- Superstructures

APPLIED TO

- Concrete
- Masonry
- Steel
- Timber
- Insulation Board



TYPICAL USES

RIW Flexiseal, as a system, is used in all situations where a high performance tanking or damp proof membrane is required. Suitable substrates include concrete, masonry, steel, asbestos cement, timber, sprayed polyurethane foams and expanded polystyrene such as ICF systems.

RIW Flexiseal primer is used to seal porous or contaminated surfaces, and to aid adhesion of the membrane.

When designing Type A structures (as classified in BS 8102 : 1990), the product applied correctly is capable of providing the levels of protection required for Grades 1, 2, 3 & 4 basements

RIW Flexiseal is not to be used in contact with potable water systems.

DURABILITY

Subject to normal conditions of use RIW Flexiseal will provide an effective barrier to the transmission of liquid water and water vapour for the life of the structure.

SPECIFICATION

J 30 – Liquid Applied Tanking / Damp Proofing in accordance with NBS Clauses.

Please consult RIW Limited for further information.

ANCILLARY PRODUCTS

RIW produce a range of ancillary products for use with RIW Flexiseal which include :-

RIW Cementfill FC - Cement based waterproof fairing coat and repair mortar for filling minor holes, voids and defects.

RIW Cementfill HB - Cement based waterproof high build repair mortar for profiling and providing fillets.

RIW Cleaning Solvent - a liquid for cleaning tools, equipment, etc. (must not be used as thinners).

RIW Double Drain - a drainage board which protects the membrane during backfilling operations, and also promotes drainage of water away from the structure.

RIW Protection Board - a 3mm bitumen impregnated, rot proof, board to prevent damage to the waterproof membrane during backfilling operations.

RIW Sheetseal 9000 DPC - a range of high performance polymeric dpc's, and pre-formed cavity trays, compatible for use with all RIW Limited membranes.

PERFORMANCE & COMPOSITION

	RIW FLEXISEAL PRIMER / SEALER	RIW FLEXISEAL MEMBRANE
Form	liquid	Thixotropic liquid
Colour	Hazy pale brown	Black or grey
Specific Gravity	1.22 g / ml	1.25 g / ml
Solids content	100% (w / w)	100% (w / w)
Flash point	200°C	250°C
Coverage*	8m ² / litre	2m ² / kg / coat
Number of coats	One, minimum	Two
DFT of coating	75 microns	0.8mm for two coats
Minimum lap		100mm
Curing time	As a primer : 2 – 4 hours (slightly tacky) As a concrete sealer : 12 hours	Touch dry : 6 hours minimum Full chemical cure : 7 days
Overcoating time	Minimum : 2 hours (4 hrs. onto bituminous surfaces) Maximum : 48 hours	Minimum : when touch dry Maximum : 48 hours
Elongation	N / A	500%
Tensile strength	N / A	650 psi
Application temperature limits	5 – 35°C	5 – 35°C
Preparation of liquid	None	Stir well by mechanical means
Shelf life: from date of manufacture	9 months	9 months (Temperate climate)

PHYSICAL / CHEMICAL RESISTANCE (SPILLAGES)

Sulphate resistance	N / A	50,000 ppm
U.V. resistance	N / A	Good
Brine	N / A	Resistant
Dilute mineral acids	N / A	Resistant
Dilute alkali solutions	N / A	Resistant
Bleach	N / A	Resistant
Anti-freeze	N / A	Resistant
Lubricating oil	N / A	Resistant
White spirit	N / A	Resistant
50% Caustic Soda	N / A	Resistant

The above performance figures are typical values and should not be considered a product specification.

*Figures quoted are theoretical coverage rates. Actual coverage may vary depending on nature of substrate.

CONSTRUCTION

GENERAL

All construction should conform with The Building Regulations, Codes of Practice, and British Standards in current use at the time the building is being constructed. In particular, it is recommended that reference is made to BS 8102 : 1990.

PREPARATION

All Surfaces : Should be smooth, clean, dry (to a depth of 1 - 2mm), sound and free from frost, oil, grease, condensation and other contamination. Any voids or hollows must be made good to a flush finish, with a suitable filler. Any sharp edges or high points should be eliminated. Powdery or flaking surfaces should be removed by suitable means.

External corners should be chamfered or rounded where required, to assist application.

Concrete Surfaces : Horizontal surfaces should preferably be smooth, however lightly tamped (3 - 4mm peak to trough profile), brushed or floated surfaces may also be acceptable.

Masonry : Should be sound with joints flush pointed or 'bagged out' with RIW Cementfill FC or similar before the membrane is applied. Open textured surfaces should be sealed with RIW Cementfill FC or a sand/cement slurry or render to provide a suitable surface. If existing surfaces are very rough, they may require rendering.

Metal surfaces : Should be wire brushed or sand blasted and pre-treated with a steel primer prior to the application of the RIW Flexiseal Primer and RIW Flexiseal. Corroded metal should also be treated with an anti-corrosive primer. RIW Flexiseal Primer is compatible with all commonly encountered steel primers including alkyd, chlorinated rubber and epoxy based paints.

APPLICATION

General : Application of RIW Flexiseal and Flexiseal Primer should not be attempted in temperatures below 5°C. Apply one coat of RIW Flexiseal Primer to all surfaces, unless otherwise noted. RIW Flexiseal Primer must be allowed to become tacky before overcoating, or dry when used on bituminous surfaces.

Do not apply primer onto existing membrane at overlaps, etc., unless directed otherwise.

RIW Flexiseal and RIW Flexiseal Primer should not be thinned and should be applied as supplied. The grey base coat should be applied first, to a primed surface. The black top coat should then be applied onto the dry base coat. The coverage rates and overcoating times in the performance table should be followed in all cases. The material is of a thixotropic nature and should be stirred using a mechanical stirrer immediately before use. Under certain circumstances such as cold weather conditions application can be made easier by 'warming' the product in a hot water bath during use.

Do not allow water to enter the product. Do not use naked flames, or heat the material above 35°C. Brushes, etc. should be cleaned and dried immediately after use, or discarded.

Manual : RIW Flexiseal should be applied using a stiff brush, or squeegee, however, medium pile rollers can be used, if preferred.

Spray : For further information and details of Specialist Applicators, please consult the RIW Technical Department.

QUALITY CONTROL

The use of a two colour system allows the easy identification of any areas that have been missed with the second coat. The overall thickness of the membrane may be tested when cured by using a sharp knife to remove a small sample of the RIW Flexiseal and measuring with a micrometer. The test patch may then be re-treated with a single application. The cutting and re-treatment of the test patch area will not affect the overall integrity of the membrane, consult RIW Limited for further advice.

DETAIL 1 EXTERNAL TANKING

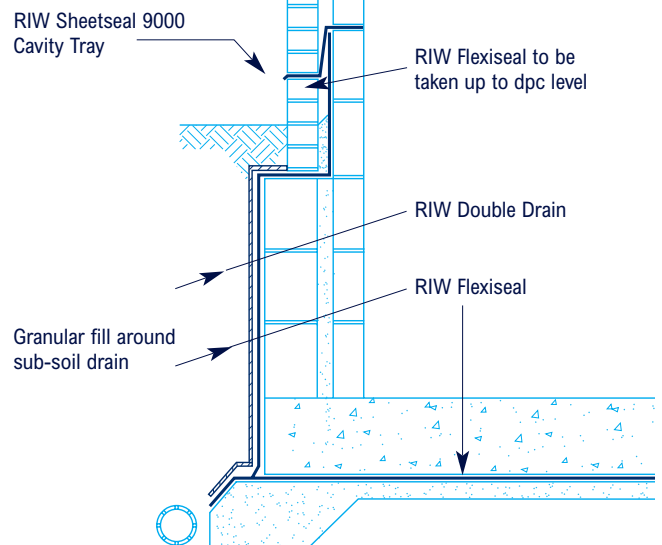

DETAIL 2 INTERNAL TANKING

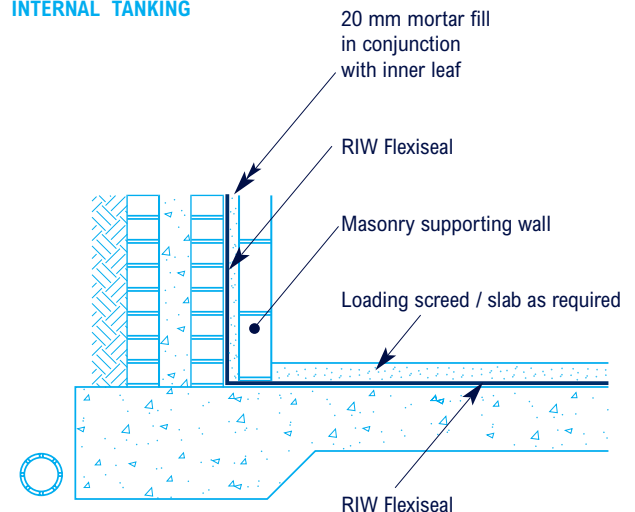

DETAIL 3
GROUND FLOOR DPM

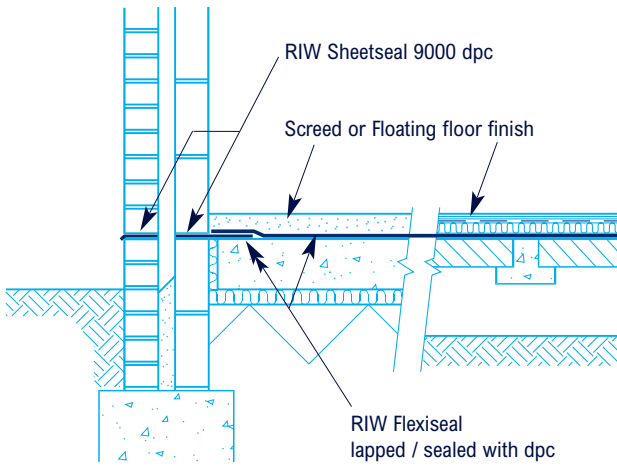

DETAIL 6
PIPE / SERVICE ENTRY DETAIL

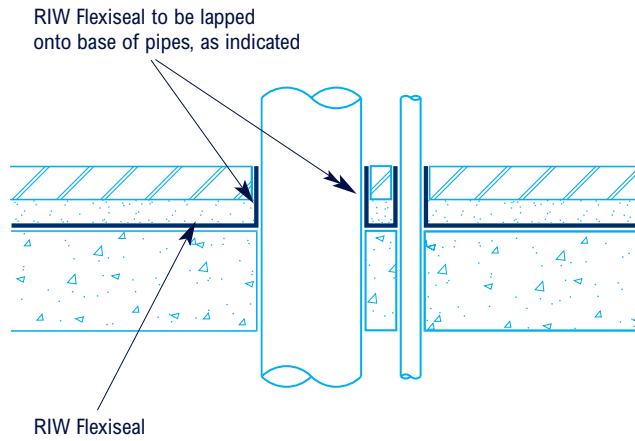

DETAIL 4
DRAINAGE OUTLET DETAIL

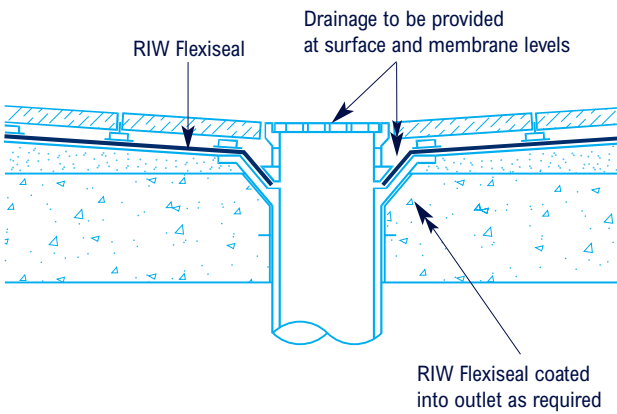

DETAIL 7
EXPANSION / MOVEMENT JOINT

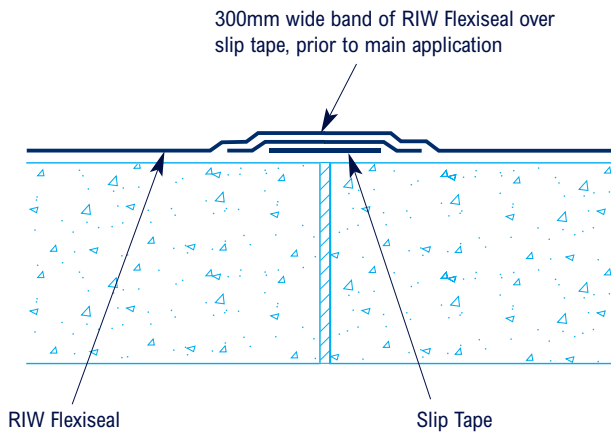

DETAIL 5
STEEL COLUMN BASE

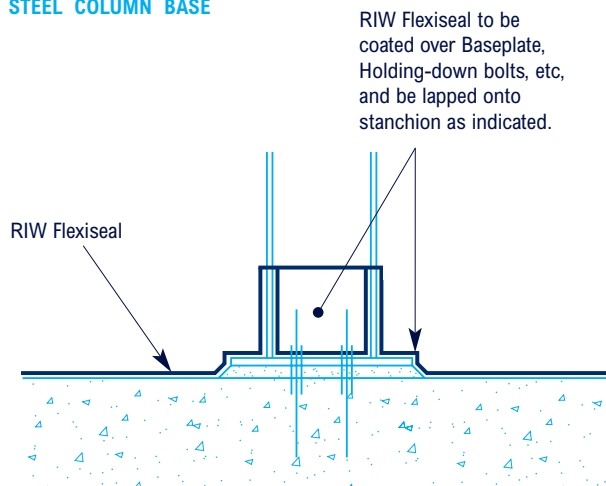

SPECIFIC USES

Tanking : RIW Flexiseal should always be fully supported, to resist hydrostatic pressure, when used for tanking.

External tanking : Should be carried out as illustrated in Detail 1 of this literature. The horizontal membrane should be laid on a concrete blinding to project at least 150mm beyond the outer face of the structure. The base structural slabs and the walls should be formed, and the vertical membrane should then be applied. The membrane should then be protected from backfilling using RIW Double Drain or RIW Protection Board, to suit.

Internal tanking : Should be carried out as illustrated in Detail 2 of this literature. A loading coat of brick, block or concrete should be constructed immediately after the membrane has cured. If brick or block is used, a 20mm minimum cavity should be left between the membrane and the loading skin. This cavity must be filled with sand / cement mortar fill as work proceeds.

Deck Areas : Should be laid to falls to outlets as necessary. The membrane should be covered and protected as soon as possible after application.

Movement joints : Joints subject to movement should be treated as illustrated in Detail 7 of this literature. The use of a slip tape debonds the RIW Flexiseal allowing dissipation of stresses over a wide area. In certain circumstances, specific movement jointing systems may be required.

SAFETY

RIW Flexiseal products can affect sensitive skins. Gloves or barrier cream should always be used by operatives and hands should be thoroughly washed at the end of each working period. Normal levels of air change are acceptable, however wear a suitable respirator if application is in an enclosed space. Do not allow the product to enter watercourses. Full health and safety instructions are contained on the product material safety data sheets, and these must be referred to before use.

SUPPLY

AVAILABILITY

All RIW products can be obtained through Builders Merchants or approved stockists. A list of approved stockists is available from RIW Ltd's offices.

PACKAGING

RIW Flexiseal	6 kg and 25 kg containers
RIW Flexiseal Primer	5 and 20 litre containers

STORAGE

The shelf life of unopened containers is approximately nine months from date of manufacture which is noted on the container. Once opened Flexiseal should be used immediately. Drums must not be stored in direct sunlight and should be handled with care, a dented drum may allow ingress of air with premature curing.

TECHNICAL SERVICES

The RIW Technical Department is available to advise on individual projects and to prepare or assist in the preparation of specifications and drawings. A list of experienced applicators of RIW materials is available from RIW Ltd's offices.

The information in this literature was correct at the time of going to press. However, we are committed to continually improving our products and reserve the right to change product specifications. For the latest information, please consult RIW Limited. Conditions of use are beyond our control, therefore we can not warrant the results to be obtained.



RIW Limited

Arc House, Terrace Road South, Binfield, Bracknell, Berkshire RG42 4PZ

Technical enquiries tel: **01344 397777**

Commercial enquiries tel: **01344 397788**

www.riw.co.uk

