

MULTI-WIDTH INSULATED SUPAFIX CAVITY CLOSER

DACATIE
BUILDINGSOLUTIONS

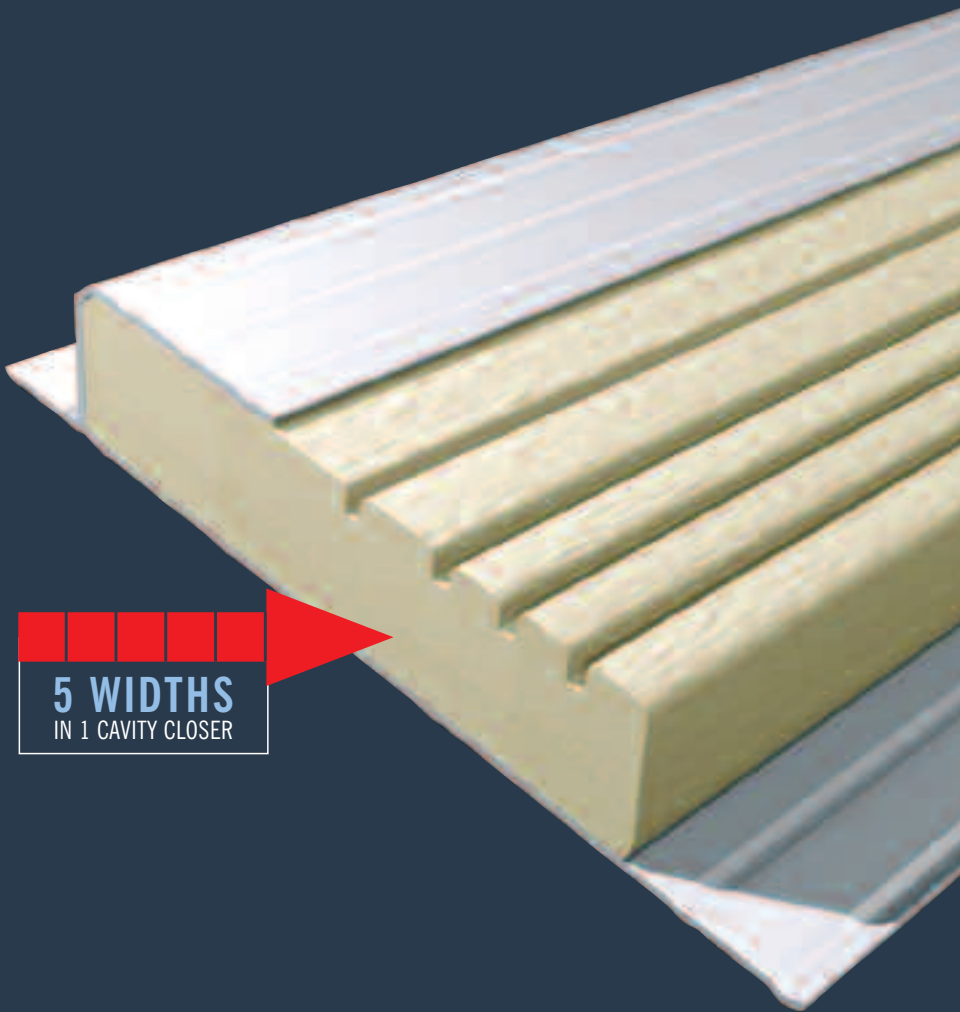

5 WIDTHS
IN 1 CAVITY CLOSER



RECOMMENDED FOR CLOSING THE CAVITY AROUND WINDOW AND DOOR OPENINGS IN SECOND FIX INSTALLATIONS WHEN A FRAME FORMER IS NOT REQUIRED



Supafix Multicloser

Features



- Complies with new Part L Building Regulations
- Reduces risk of condensation, mould & moisture migration across the cavity
- Overcomes cavity width variations
- Weather resistant
- Easy to install
- No ties required - simply nail to blocks
- Can be used on timber frame construction

Specifications

Profile
White non water-absorbing PVCu

Insulation
EPS insulation, HCFC & HFC free

Lengths	Widths
2.4 metres	50,65,75,85 & 100mm

Minimal thermal resistance path
0.45m²/KW

Regulations

Approved Document Part L revised 2002

With 30mm window frame set-back, complies with thermal requirements. BBA approved for moderate and sheltered conditions

Manufactured to ISO9001

Order codes

Standard: SF Multicloser

D3000

INSULATED CAVITY CLOSER

D2000

INSULATED CAVITY CLOSER

D2000 FIRE RATED

INSULATED CAVITY CLOSER

Frame Formers

INSULATED CAVITY CLOSER

TF8i

INSULATED CAVITY CLOSER

Supafix FIRE RATED

INSULATED CAVITY CLOSER

Supafix

INSULATED CAVITY CLOSER

DPC

INSULATED DPC

Weepholes

Supafix Multicloser

DACATIE
BUILDINGSOLUTIONS

- 5 cavity widths with one profile
- Easily trim to cavity width on site
- Economic

Supafix Multicloser is a versatile insulated cavity closer that is easy to use to achieve building regulations where cavity widths are unknown or vary on site. The product is a particularly useful solution in a second fix installation when a frame former is not required.

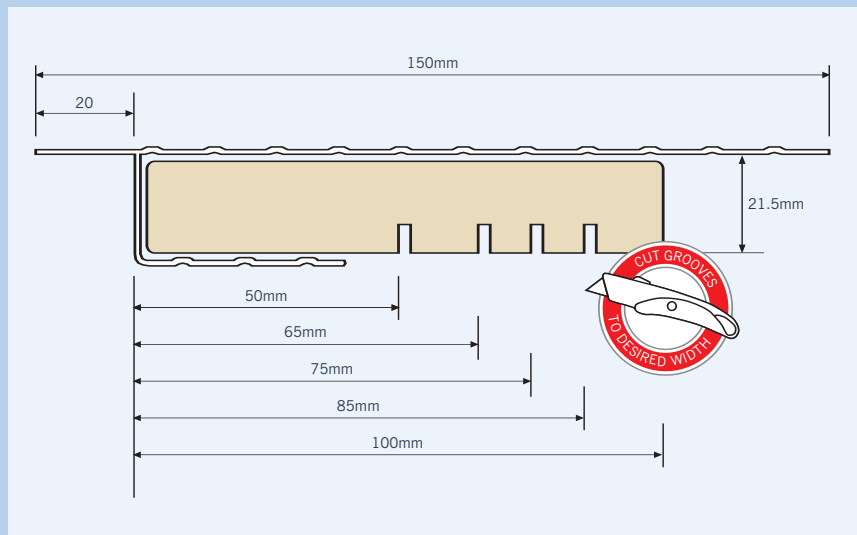
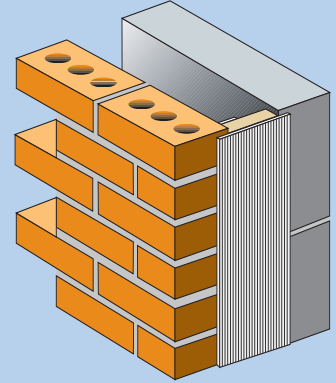

Installation

SF-Multicloser has pre cut grooves to simplify cutting the closer to the required cavity width. The closer will suit 50mm, 65mm, 75mm, 85mm and 100mm cavity widths.

Simply cut along the groove of the appropriate cavity width with a sharp knife. Cut the profile to the respective height and widths of the cavity opening and then 'push fit' into the cavity. Slight cavity width variations can be overcome by applying a small pressure.

The ribbed surface of SF-Multicloser will accept wet plaster, or plasterboard on dabs. Best practice would suggest priming the closer surface prior to finishing.

SF-Multicloser is available in 2.4 metre lengths and suitable for cavities between 50mm and 100mm.

QUANTUM PROFILE SYSTEMS LTD.
SALMON FIELDS ROYTON OLDHAM
LANCASHIRE OL2 6JG

SALES & TECHNICAL SUPPORT
0161 622 2020
f: 0161 622 2022 e: sales@dacatie.co.uk